



## APPLICATIONS

- Single Frequency networks in FM (linear and/or surficial)
- Perfect synchronization of audio, MPX or direct RF for FM transmitters or amplifiers

## KEY BENEFITS

- Field Proven: Used in France (over 200 sites)
- Can be used with amplifier (RF output)
- IP based Distribution Network
- ETI over IP Input : Optimized IP bit rate due to MPEG ½ Layer 2 Encoding
- MPX over IP Input: Lossless MPX distribution
- Extremely precise synchronisation (less than 1 µs)
- Double power supply as an option
- 2 identical digital MPX outputs for the model with digital MPX output

## REAR PANEL MODEL WITH AES OUPUTS



## REAR PANEL MODEL WITH RF OUPUT



## TECHNICAL SPECIFICATIONS

### INPUTS / OUTPUTS

1 x IP input on Ethernet 10/100 Base-T – RJ45 connector

With either ETI FM Multiplex over IP Input or MPX over IP input (to be selected at purchase)

1 x GPS Aerial Input on 50Ω TNC connector

Model 1 : 2 x Digital AES/EBU Audio Output (48 kHz)

on 1 female XLR connectors (110Ω balanced)

Model 2: 2 x Digital MPX output at 192kHz AES/EBU format on 1 female XLR connectors (110Ω balanced)

Model 3 : 1 x 50Ω RF Output (76 MHz to 108 MHz 0 dBm.

Left Right Separation 65 dB SNR 70 dB) on BNC connector

2 x 10/100/1000 Base-T Ethernet Data port on RJ45 connector (one for IP input)

PPS output on BNC connector

### CONTROL AND MONITORING

Remote control through a web server or and monitoring through SNMP (MIB supplied)

Local monitoring with the LCD front panel

### FEATURES

2 Types:

- Type1 : MPX transport with MPX over IP input
- Type2 : MPEG 1/2 Layer2 encoding with ETI FM Multiplex over IP Input

Decapsulation of IP Input with separation and analysis of audio/MPX and RDS data information

Time stamp management

MPEG ½ Layer 2 audio decoding over DCP (Type1)

192kHz MPX over DCP (Type 2)

Internal GPS receiver module with NTP server

Synchronization with time stamps and GPS input

FM RF or MPX outputs with FM stereo and RDS

### ELECTRICAL

AC Input: 110-240 V, 50/60 Hz

Power consumption: < 40W

Option : Double Power Supply

### MECHANICAL

Dimensions and weight: 1RU:  
483 x 250 x 44 mm ; 4 kg

Temperature Range:

- Operating: 0°C to 50°C
- Storage: -20°C to 70°C

Humidity: 10% to 80% at 50°C

## BLOCK DIAGRAM

### MPXA Input (MPX over IP)

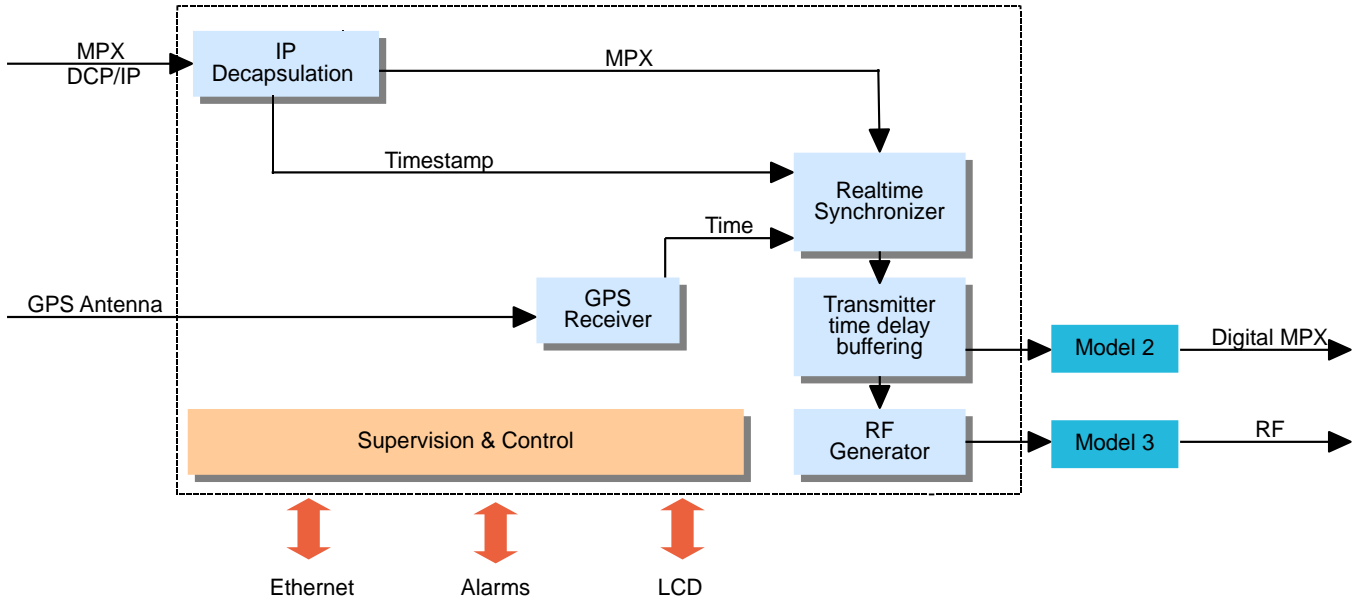

### EDI Input (ETI over IP)

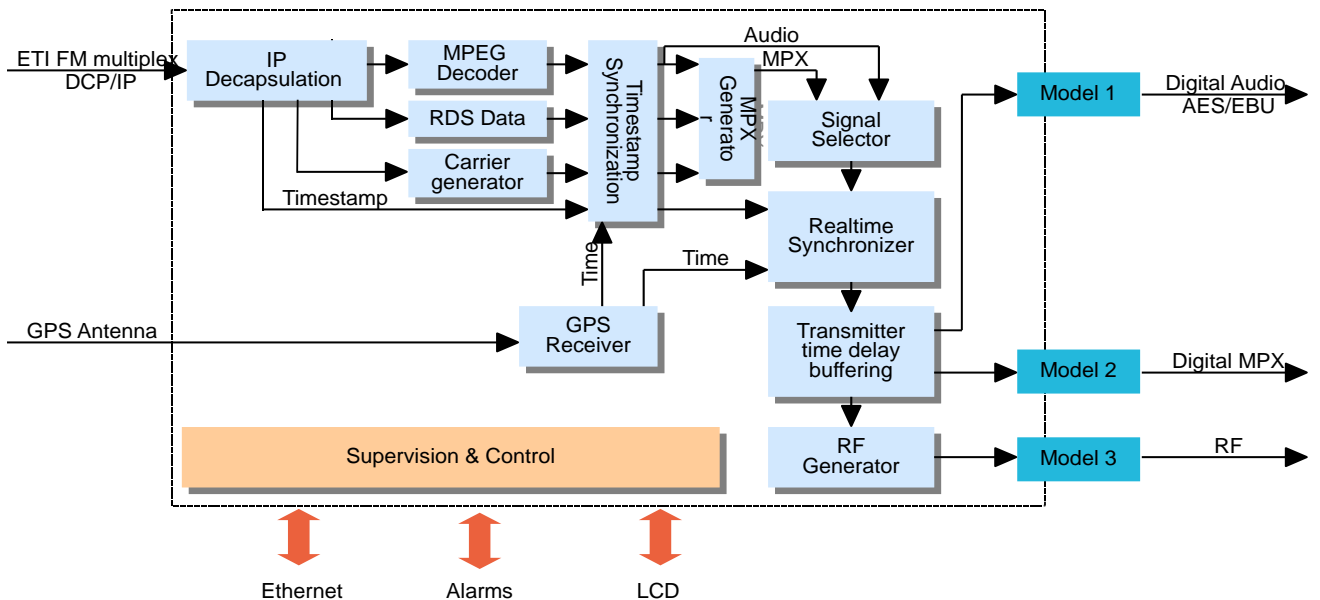

## ORDERING INFORMATION

~ SFM-DIGAUD	Model 1: SyncFM Synchronous FM Decoder with digital (AES/EBU) audio output
~ SFM-DIGMPX	Model 2: SyncFM Synchronous FM Decoder with digital MPX output
~ SFM-RFOUT	Model 3: SyncFM Synchronous FM Decoder with direct RF output
~ OPT-Dual PS	Optional second-back up power supply, working in parallel with the main power supply
~ SFM-MPXA INPUT	MPXA Input for receiving MPX over IP uncompressed audio
~ SFM- EDI INPUT	ETI over IP Input for receiving ETI FM mux over IP with MPEG 1/2 Layer 2 encoded audio